

# Hydrants, Super Centurion with Straight Connection

- ⓓ Hydranten, Super Centurion mit geradem Anschluß
- ⓕ Poteaux incendie, Super Centurion avec Entrée droite

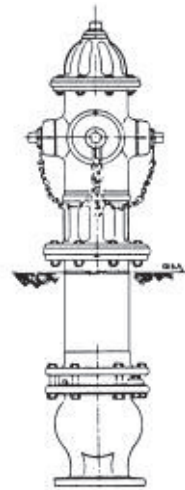

**SUPER CENTURION STRAIGHT**



Art. Nr. A-311, 1.1/2" Pentagon

## Model Super Centurion + Straight Conn./mit geradem Anschluß/avec Entrée droite

Art. Nr.	Model Modèle	Shoe Fuß Sabot	2/3 Way 2/3 Voies	Hose nozzle Schlauchanschluß Lance	Pumper nozzle Pumpenanschluß Buse Autopompe	Main Valve Hauptventil Vanne Principale	Bury Länge Profondeur	kg	FM
420-513664	A420	4"PN10	2	2x2.1/2	-	114	1067	170	
420-511536	A420	4"ANSI	2	2x2.1/2	-	114	1219	170	
421-500357	A421	6"ANSI	3	2x2.1/2	4.1/2	114	1067	180	√
421-511535	A421	6"ANSI	3	2x2.1/2	4.1/2	114	1219	180	√

Max. 13.8 Bar [200 Psi] - 2-Way/2-Wege/2 voies  
Max. 17.2 Bar [250 Psi] - 3-Way/3-Wege/3 voies

Order by specification.

Examples of art. nr with standard US outlets

Bestellung mit Spezifikation.

Beispiele der Art. Nr. mit standard US Abgängen

Commande selon spécifications

Exemples de références avec des sorties US standard

## Parts List/Bauteil-Spezifikation/Caractéristiques Techniques

Nr.	Description Umschreibung Description	Material Material Matériau
1	Operating nut/Bedien-Vierkantmutter/Carré de manoeuvre	Bronze/Bronze/Bronze
2	Wiper ring/Abstreifring/Segment racleur	Rubber/Gummi/Caoutchouc
3	Hold down nut "O" ring/"O" Ring, Haltemutter/Joint torique d'écrou de retenue	Rubber/Gummi/Caoutchouc
4	Hold down nut/Haltemutter/Ecrou de retenue	Bronze/Bronze/Bronze
5	Bonnet "O" ring/Deckel "O" Ring/Joint torique de chapeau	Rubber/Gummi/Caoutchouc
6	Anti-friction washer/U-Scheibe gegen Reibung/Rondelle anti-friction	Plastic/Plastik/Plastique
7	Oil filler plug/Ölfüllstopfen/Obturateur de remplissage d'huile	Brass/Rotguß/Laiton
8	Bonnet/Deckel/Chapeau	Cast iron/Grauguß/Fonte
9	Bonnet Bolts/Deckelschrauben/Boulons de chapeau	Steel/Stahl/Acier
10	Bonnet Gasket/Gehäusedeckeldichtung/Joint de chapeau	Rubber/Gummi/Caoutchouc
11	Upper stem/Obere Spindel/Tige supérieure	Steel/Stahl/Acier
12	Stem "O" rings/Spindel "O" Ringe/Joins toriques de tige	Rubber/Gummi/Caoutchouc
13	Nozzle lock/Sperre, Anschluß/Verrou de lance	Stainless steel/Edelstahl/Inox
14	Pumper nozzle/Pumpenanschluß/Sortie autopompe	Bronze/Bronze/Bronze
15	Pumper nozzle gasket/Pumpenansch. Dichtung/Joint de buse autopompe	Rubber/Gummi/Caoutchouc
16	Pumper nozzle "O" ring/Pumpenansch."O" Ring/Joint torique buse autop.	Rubber/Gummi/Caoutchouc
17	Pumper nozzle cap/Pumpenansch. Kappe/Bouchon buse autop.	Cast iron/Grauguß/Fonte
18	Hose nozzle/Schlauchanschluß/Sorties lances	Bronze/Bronze/Bronze
19	Hose nozzle gasket/Schlauchansch. Dichtung/Joint de lance incendie	Rubber/Gummi/Caoutchouc
20	Hose nozzle "O" ring/Schlauchansch. O-Ring/Joint torique lance.	Rubber/Gummi/Caoutchouc
21	Hose nozzle cap/Schlauchansch. Kappe/Bouchons buses lances	Cast iron/Grauguß/Fonte
22	Chains/Ketten/Chaines	Steel/Stahl/Acier
23	Chain connector hook/Kettenanschlußhaken/Crochet fixation chaîne	Steel/Stahl/Acier
24	Upper barrel/Oberer Teil d. Hydranten/Corps supérieur	Cast iron/Grauguß/Fonte
25	Safety stem coupling/Sicherh. Spindelkuppl./Raccord tige sécurité	Steel/Stahl/Acier
26	Safety flange bolt/Sicherh.Flanschbolzen/Boulon bride sécurité	Steel/Stahl/Acier
27	Safety flange gasket/Sich. Flanschdichtung/Joint bride sécurité	Rubber/Gummi/Caoutchouc
28	Safety flange/Sicherheitsflansch/Bride de sécurité	Cast iron/Grauguß/Fonte
29	Cotter pins/Splint/Goupilles fendues	Stainless steel/Edelstahl/Inox
30	Clevis pins/Gabelbolzen/Broches	Stainless steel/Edelstahl/Inox
31	Lower stem/Untere Spindel/Tige inférieure	Steel/Stahl/Acier
32	Lower barrel/Unterer Teil d. Hydranten/Corps inférieur	Cast iron/Grauguß/Fonte
33	Stem pin/Spindelstift/Goupille tige	Stainless steel/Edelstahl/Inox
34	Drain valve facing/Entleerungsventil Dicht./Revêtement vanne vidange	Plastic/Plastik/Plastique
35	Drain valve facing screw/Schraube für Nr. 34/Revêtement écrou vanne de purge	Stainless steel/Edelstahl/Inox
36	Upper valve plate/Obere Ventilplatte/Plaque supérieure de vanne	Bronze/Bronze/Bronze
37	Shoe bolt/Schraube f.Hydr.Fuß/Vis du sabot	Steel/Stahl/Acier
38	Drain ring housing gasket/Entleer.Ringdichtung/Joint d'anneau de purge	Rubber/Gummi/Caoutchouc
39	Top seat ring "O" ring/Oberer Sitz "O" Ring/Joint torique siège supérieur	Rubber/Gummi/Caoutchouc
40	Drain ring housing/Entleer.Ring Gehäuse/Carter bague de purge	Cast iron/Grauguß/Fonte
41	Drain ring housing bolt/Schraube Entleer.Ring/Boulon de carter bague de purge	Steel/Stahl/Acier
42	Drain ring/Entleerungsring/Bague de purge	Bronze/Bronze/Bronze
43	Seat ring/Sitzring/Anneau de siège	Bronze/Bronze/Bronze
44	Bottom seat ring "O" ring/Unterer Sitz "O" Ring/Joint torique siège inf.	Rubber/Gummi/Caoutchouc
45	Main valve/Hauptventil/Vanne principale	Rubber/Gummi/Caoutchouc
46	Lower valve plate/Ventilplatte unten/Plaque vanne inf.	Cast iron/Grauguß/Fonte
47	Cap nut seal/Kappenmutter-Dichtung/Joint écrou borgne	Rubber/Gummi/Caoutchouc
48	Lock washer/Sprengring/Rondelle frein	Stainless steel/Edelstahl/Inox
49	Cap nut/Kappenmutter/Ecrou borgne	Cast iron/Grauguß/Fonte
50	Shoe/Fuß/Sabot droit	Cast iron/Grauguß/Fonte

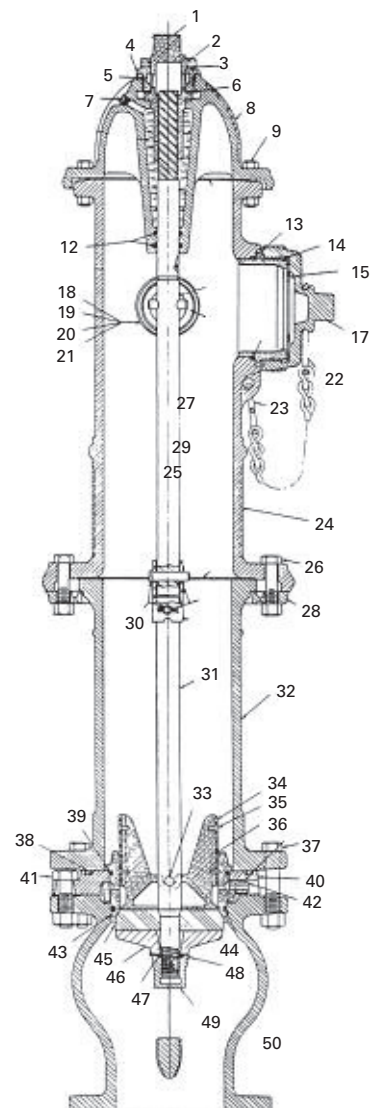

# Hydrants, Super Centurion with Duck Foot

**D** Hydranten, Super Centurion mit Entenfuß

**F** Poteaux Incendie, Super Centurion avec Entrée coudée



**SUPER CENTURION DUCKFOOT**

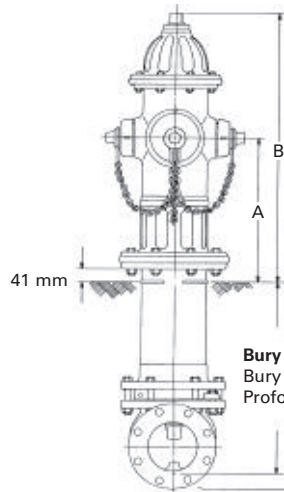

Art. Nr. A-311, 1.1/2" Pentagon

Bury depth of 1'6" minimum. Longer versions can be ordered in 6" intervals/  
Bury - 1'-6" Minimum. Länger in 6" Intervallen/  
Profondeur - 1'-6" Minimum. Plus longue par intervalles de 6"

ANSI 125 Flanged/Flansche ANSI125/Bride ANSI125-6"

## Model Super Centurion + Duck Foot/mit Entenfuß/avec Entrée coudée

Art. Nr.	Model Modèle	2/3 Way 2/3 Voies	Hose Valve/Nozzle Schlauch Ventili-Anschluss Vanne Buse Lance	Pumper nozzle Pumpen-anchluss Buse Autopompe	Main Valve Hauptventil Vanne Principale	Bury Länge Profondeur	A	B	Kg	UL	FM
				"	mm	mm	mm	mm			
433-508179	A433	2	nozzle	-	114	1219	451	794	180	✓	✓
421-500358	A421	3	nozzle	4.1/2	114	1219	451	794	185	✓	✓
435-504195	A435	2	nozzle	-	133	1219	438	784	180	✓	✓
423-500158	A423	3	nozzle	4.1/2	133	1219	438	784	185	✓	✓
433-519499	A433	2	valve A-373	-	114	1219	451	794	180	✓	✓
421-520731	A421	3	valve A-373	4.1/2	114	1219	451	794	185	✓	✓
435-519515	A435	2	valve A-373	-	133	1219	438	784	180	✓	✓

Max. 13.8 Bar [200 Psi] - 2-Way/2-Wege/2 voies  
Max. 17.2 Bar [250 Psi] - 3-Way/3-Wege/3 voies

### Order by specification.

Examples of art. nr with standard US outlets and 4' bury depth

Bestellung mit Spezifikation.  
Beispiele der Art. Nr. mit standard US Abgängen und 4' Länge(bury)

Commande selon spécifications  
Exemples de références avec des sortie US standard avec profondeur 4'[1219mm]

Nr.	Description Umschreibung Description	Material Material Matériau
1	Operating nut/Bedien-Vierkantmutter/Carré de manoeuvre	Bronze/Bronze/Bronze
2	Weather seal/Wetterdichtung/Joint d'étanchéité	Rubber/Gummi/Caoutchouc
3	Hold down nut "O" ring/"O" Ring, Haltemutter/ Joint torique d'écrou de retenue	Rubber/Gummi/Caoutchouc
4	Hold down nut/Haltemutter/Ecrou de retenue	Bronze/Bronze/Bronze
5	Bonnet "O" ring/Deckel "O" Ring/Joint torique de chapeau	Rubber/Gummi/Caoutchouc
7	Oil filler plug/Ölfüllstopfen/Obturateur de remplissage d'huile	Brass/Rotguß/Laiton
8	Bonnet/Deckel/Chapeau	Cast Iron/Grauguß/Fonte
9	Bonnet Bolts & nut/Deckelschraub.+Mutter/Boulons écrou chapeau	Steel/Stahl/Acier
10	Bonnet Gasket/Gehäusedeckeldichtung/Joint de chapeau	Rubber/Gummi/Caoutchouc
11	Upper stem/Oberer Spindel/Tige supérieure	Steel/Stahl/Acier
12	Stem "O" rings/Spindel "O" Ringe/Joins toriques de tige	Rubber/Gummi/Caoutchouc
13	Nozzle lock/Sperre, Anschluss/Verrou de lance	Stainless steel/Edelstahl/Inox
14	Pumper nozzle/Pumpenanschluss/Bouchon buse autop.	Bronze/Bronze/Bronze
15	Pumper nozzle gasket/Pumpen Anschluss Dichtung/Joint de buse autopompe	Bronze/Bronze/Bronze
16	Pumper nozzle O-Ring/Pumpen Anschluss O-Ring/Joint torique buse autopompe	Rubber/Gummi/Caoutchouc
17	Pumper nozzle cap/Pumpen Anschluss Deckel/Bouchon buse autopompe	Rubber/Gummi/Caoutchouc
18	Hose nozzle/Schlauchanschluss/Sorties lances	Bronze/Bronze/Bronze
19	Hose nozzle gasket/Schlauchanschl. Dichtung/Joint de lance incendie	Rubber/Gummi/Caoutchouc
20	Hose nozzle "O" ring/Schlauchanschl. O-Ring/Joint torique lance	Rubber/Gummi/Caoutchouc
21	Hose nozzle cap/Schlauchanschl. Kappe/Bouchons buses lances	Cast Iron/Grauguß/Fonte
23	Chains connector ring/Kettenanschluring/Crochet fixation chaîne	Steel/Stahl/Acier
22	Chain/Kette/Chaines	Steel/Stahl/Acier
24	Upper barrel/Oberer Teil d. Hydrants/Corps supérieur	Cast Iron/Grauguß/Fonte
26	Safety flange bolt & nut/Sicherh.Flanschbolz.+M/Boulon bride sécurité	Steel/Stahl/Acier
25	Safety stem coupling/Sicherh. Spindelkuppl./Raccord tige sécurité	Steel/Stahl/Acier
27	Safety flange gasket/Sich. Flanschdichtung/Joint bride sécurité	Rubber/Gummi/Caoutchouc
28	Safety flange/Sicherheitsflansch/Bride de sécurité	Cast Iron/Grauguß/Fonte
30	Clevis pins/Gabelbolzen/Broches	Stainless steel/Edelstahl/Inox
29	Cotter pins/Splint/Goupilles fendues	Stainless steel/Edelstahl/Inox
31	Lower stem/Untere Spindel/Tige inférieure	Steel/Stahl/Acier
32	Lower barrel/Untere Spindel/Corps inférieur	Cast Iron/Grauguß/Fonte
33	Stem pin/Spindelstift/Goupille tige	Stainless steel/Edelstahl/Inox
34	Drain valve facing/Entleerungsventil Dicht./Revêtement vanne de purge	Plastic/Plastik/Plastique
35	Drain valve facing screw/Schraube für Nr. 34/Revêtement écrou vanne de purge	Stainless steel/Edelstahl/Inox
36	Upper valve plate/Obere Ventilplatte/Plaque supérieure de vanne	Bronze/Bronze/Bronze
37	Shoe bolt & nut/Schraube & Mut. f. Fuß/Vis du sabot	Steel/Stahl/Acier
38	Drain ring gasket/Entleer.Ringdichtung/Joint d'anneau de purge	Rubber/Gummi/Caoutchouc
39	Top seat ring "O" ring/Oberer Sitz "O" Ring/Joint torique siège supérieur	Rubber/Gummi/Caoutchouc
42	Drain ring/Entleer.Ring Gehäuse/Bague de purge	Bronze/Bronze/Bronze
41	Drain ring bolt & nut/Schraube & Mutter f.42/Boulon de carter bague de purge	Steel/Stahl/Acier
43	Seat ring/Sitzring/Anneau de siège	Bronze/Bronze/Bronze
44	Bottom seat ring "O" ring/Unterer Sitz "O" Ring/Joint torique siège inf.	Rubber/Gummi/Caoutchouc
45	Main valve/Hauptventil/Vanne principale	Rubber/Gummi/Caoutchouc
46	Lower valve plate/Ventilplatte unten/Plaque vanne inf.	Cast Iron/Grauguß/Fonte
48	Cap nut seal/Kappenmutter-Dichtung/Rondelle frein	Rubber/Gummi/Caoutchouc
47	Lock washer/Sprengtring/Joint écrou borgne	Stainless steel/Edelstahl/Inox
49	Cap nut/Kappenmutter/Ecrou borgne	Cast Iron/Grauguß/Fonte
50	Shoe/Fuß/Sabot coudé	Cast Iron/Grauguß/Fonte
51	Hydratant lubricating oil/Hydrant Schmieröl/Huile de lubrification Poteau	
52	Plug/Stopfen/Obturateur	

